

THIS DRAWING IS UNPUBLISHED. RELEASED FOR PUBLICATION
 © COPYRIGHT - By - ALL RIGHTS RESERVED.

LOC		DIST		REVISIONS			
P	LTR	DESCRIPTION		DATE	DWN	APVD	
AD	00	C4		REVISED PER ECO-14-002693	01MAR2014	NK	RH

SPECIFICATIONS:

BREAK-BEFORE-MAKE

MATERIAL:

SLIDER, GLASS FILLED NYLON, UL94-HB, BLACK.
 BASE, GLASS FILLED PBT, BLUE.
 COVER, GLASS FILLED PBT, BLUE.
 SLIDE PLATE, STAINLESS STEEL.
 ACTUATOR, PPS, BLACK.
 ROCKER CONTACT(GOLD), COPPER ALLOY, GOLD OVER NICKEL PLATING.
 ROCKER CONTACT(SILVER), COPPER ALLOY PLUS COINED SILVER.
 FIXED CONTACT/TERMINAL (GOLD), COPPER ALLOY, GOLD OVER NICKEL PLATE.
 FIXED CONTACT/TERMINAL(SILVER), COPPER ALLOY PLUS COINED SILVER, GOLD OVER NICKEL PLATE.

ELECTRICAL:

CONTACT RATING(SILVER)-3A@115V AC OR 1.5A@230V AC
 CONTACT RATING(GOLD)-.4VA MAX@20V DC OR PEAK AC
 INITIAL CONTACT RESISTANCE-20 MILLIOHMS MAX.
 INSULATION RESISTANCE-1,000 MEGOHMS MIN @ 500V DC
 DIELECTRIC STRENGTH- 500 V RMS @ SEA LEVEL.
 LIFE EXPECTANCY- 30,000 OPERATIONS.

MECHANICAL:

OPERATING FORCE- 600+/-300 GRAMS.
 TRAVEL-.120

ENVIRONMENTAL:

OPERATING TEMPERATURE- -20°C TO +65°C
 STORAGE TEMPERATURE- -40°C TO +100°C
 SOLDER HEAT RESISTANCE- PER 109-202 CONDITION B.
 SOLDERABILITY PER EIA 364-52, CLASS 2, CATAGORY 1.



DATE CODE MARKING YMMM (YEAR, MONTH).

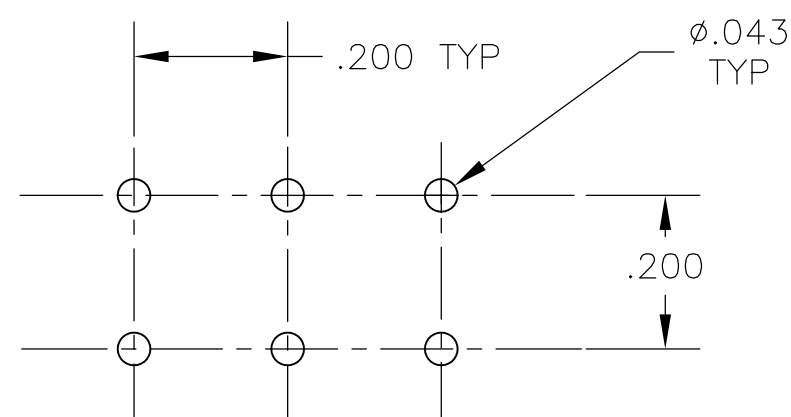
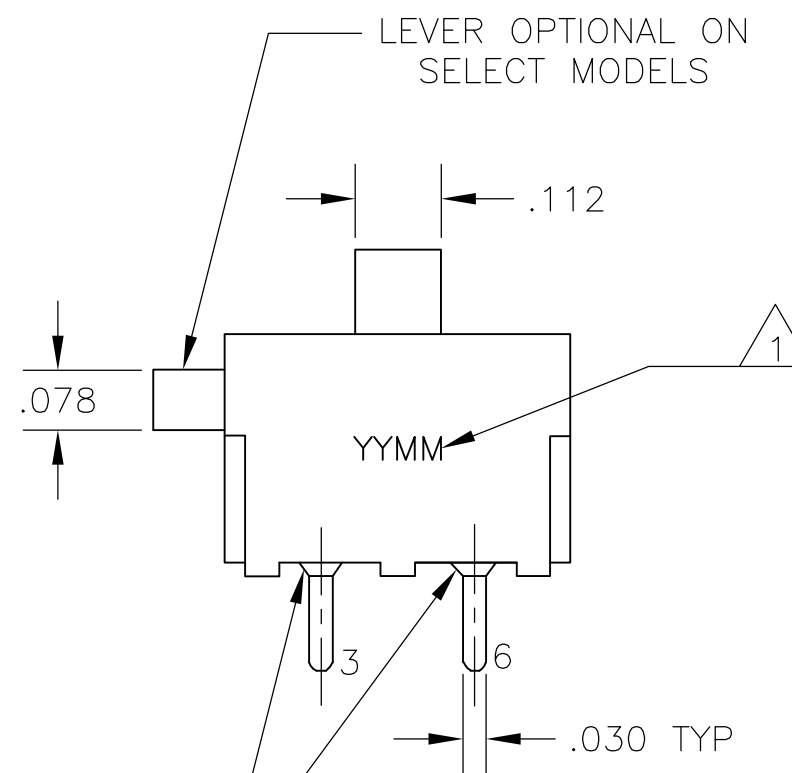
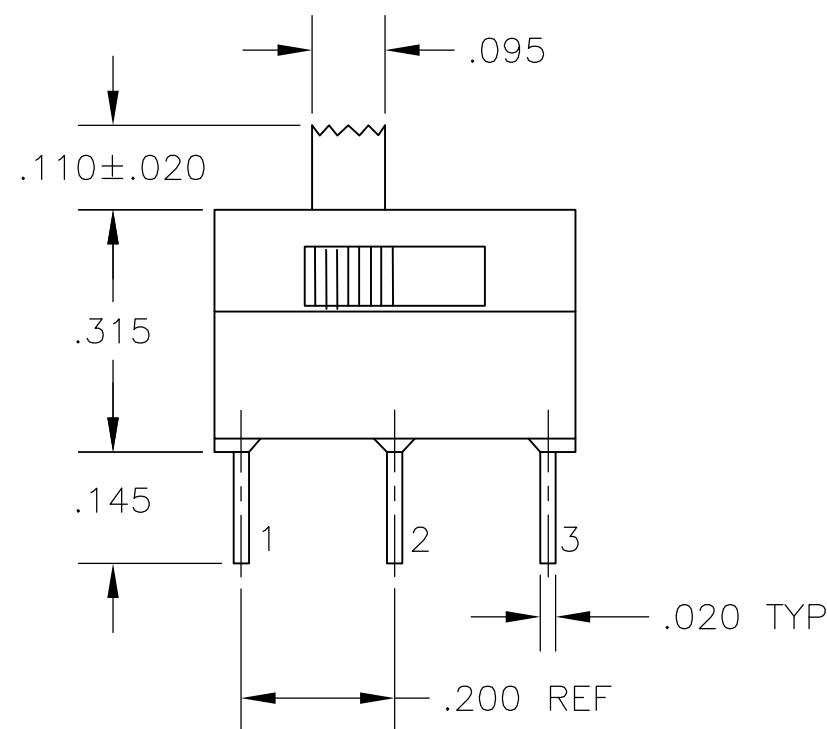
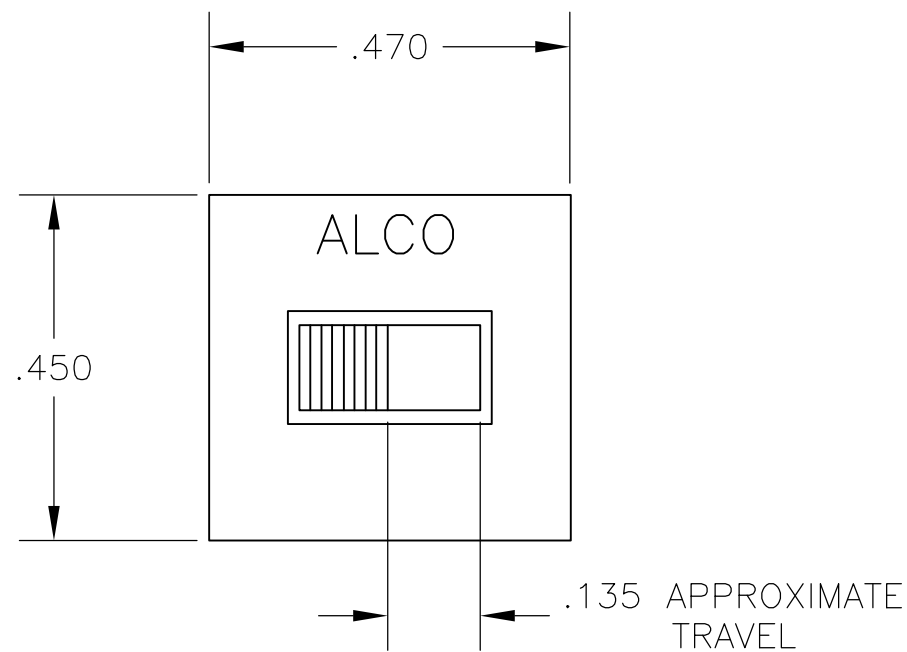

RECOMMENDED HOLE LAYOUT
 TOLERANCE ±.002 UNLESS OTHERWISE NOTED

2,1 & 5,4	NONE	2,3 & 5,6	DPDT	SILVER	MSSA214N04	5-1437580-2
2,1 & 5,4	OFF	2,3 & 5,6	DPDT	GOLD	MSSA211PG04	5-1437580-1
2,1 & 5,4	NONE	2,3 & 5,6	DPDT	GOLD	MSSA211NGRA04	5-1437580-0
2,1 & 5,4	NONE	2,3 & 5,6	DPDT	GOLD	MSSA211NG04	4-1437580-9
			TYPE	PLATING	ALCO PART NO.	PART NO.

THIS DRAWING IS A CONTROLLED DOCUMENT.		DWN	R BROWN	20APR04
DIMENSIONS: INCHES		CHK	M SARVER	20APR04
TOLERANCES UNLESS OTHERWISE SPECIFIED:		APVD	M SARVER	20APR04
0 PLC	± -	NAME		
1 PLC	± -	SLIDE SWITCH, DP (MSS-211 & 214)		
2 PLC	± -	PRODUCT SPEC	SIZE	CAGE CODE
3 PLC	± .010	APPLICATION SPEC	A2	00779
4 PLC	± -	WEIGHT	DRAWING NO	
ANGLES	± 1°	CUSTOMER DRAWING	C=4-1437580-9	
FINISH	-	SCALE	4:1	SHEET 1 of 1
		REV	C4	

4-1437580-9